

TS-A4672R 150 W MAX.

Flush-Mount Car Speaker
4" x 6" (95 mm x 153 mm)
COAXIAL 3-WAY

Haut-Parleurs à Montage Encastré
Pour Automobile
3 VOIES COAXIAL 95 mm x 153 mm

Altavoz De Montaje Al Ras Para
Automóvil
95 mm x 153 mm COAXIAL DE 3 VIAS

Be sure to read this instruction manual before installing this speaker.
Prière de lire obligatoirement ce manuel d'installation avant de
monter les haut-parleurs.

Antes de instalar el altavoz es importante que lea estas instrucciones.
Leia este manual de instruções antes de instalar o alto-falante.

- EXAMPLE OF MOUNTING
- EJEMPLO DE MONTAJE
- EJEMPLO DE MONTAJE
- EXEMPLO DE MONTAGEM

MAKE	MODEL	YEAR	FACTORY LOCATION	ILLUSTRATION	
CONSTRUCTEUR	MODELE	ANNEES	EMPLACEMENT	ILLUSTRATION	
FABRICANTE	MODELO	AÑOS	UBICACIÓN DE LA FÁBRICA LOCALIZAÇÃO DA FÁBRICA	ILUSTRACIÓN	
FABRICANTE	MODELO	ANOS	LOCALIZAÇÃO DA FÁBRICA	ILUSTRACIÓN	
GM	BUICK	SKYLARK	1992~1998	FRONT DOOR	A
		LE SABRE CUSTOM	1992~1999	DASHBOARD	C
	CHEVROLET/GMC	CAVALIER	1995~2005	FRONT DOOR	A
		ASTRO / SAFARI	1996~2005	REAR PILER	E
		MALIBU	1997~2003	FRONT DOOR	A
		CAPRICE CLASSIC / IMPALA SS	1991~1996	FRONT DOOR	A
		S-10 BLAZER / PICKUP	1982~2005	DASHBOARD	D
		S-15 JIMMY / PICKUP	1982~2005	DASHBOARD	D
		SUBURBAN	1992~1994	DASHBOARD	C
		BLAZER / YUKON FULL SIZE	1992~1994	DASHBOARD	C
		CK-PICKUP / SIERRA FULL SIZE	1988~1994	DASHBOARD	C
			1995~1999	REAR SIDE	E
	CK-PICKUP EXTENDED CAB	1997~1999	DASHBOARD	C	
	SILVERADO / SIERRA	1999~	REAR SIDE	E	
PONTIAC	GRAND AM	1992~1998	FRONT DOOR	A	
	GRAND PRIX	1988~1991	DASHBOARD	D	
	BONNEVILLE	1987~1991	DASHBOARD	D	
		1992~1999	FRONT DOOR	B	
CADDSMOBILE	ACHIEVA	1992~1998	FRONT DOOR	A	
V.W.	GOLF	1983~1998	REAR SIDE	G	
MERCEDES	S SERIES	1986~1991	DASHBOARD	F	

- HOW TO INSTALL
- MODE D'INSTALLATION
- INSTALACION
- COMO INSTALAR

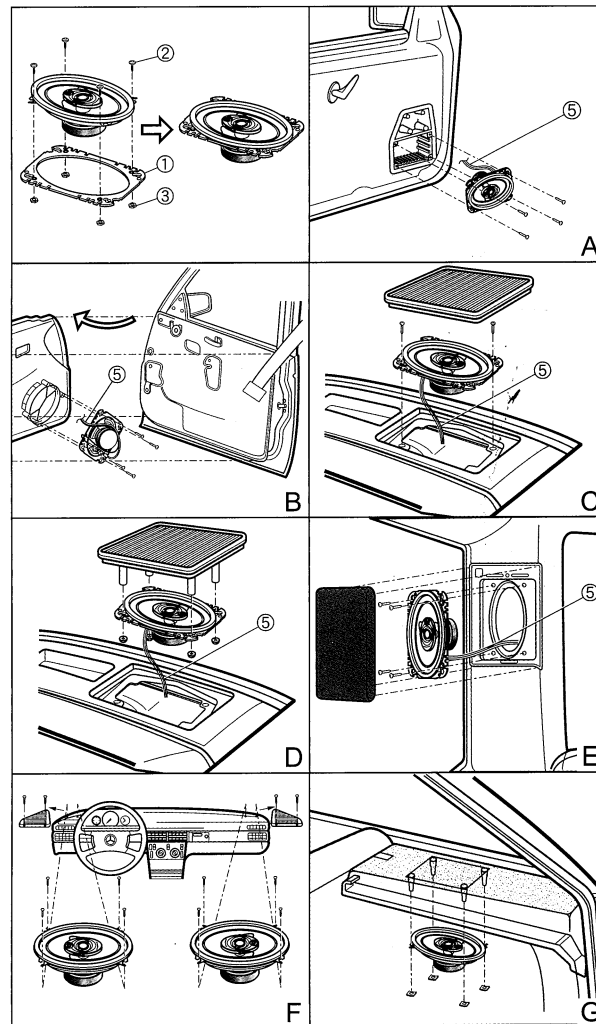

Register your product at / Enregistrez votre produit au : <http://www.pioneerelectronics.com>

Pioneer

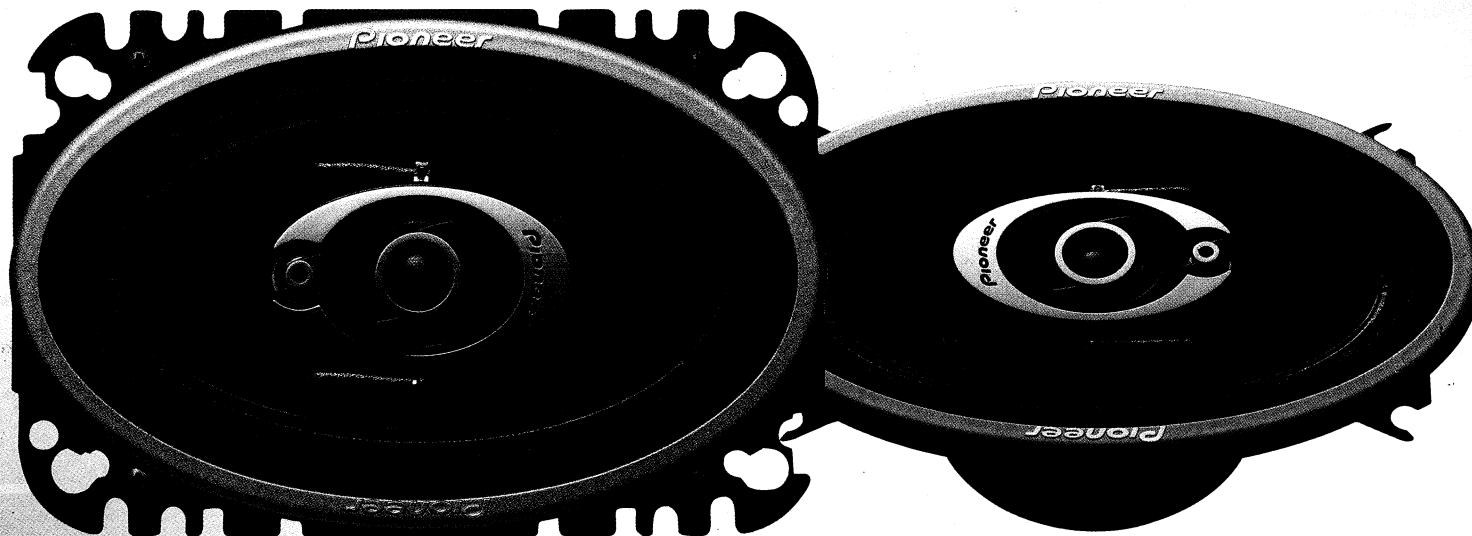

<http://www.pioneerelectronics.com>

TS-A4672R

3-Way Speaker / HP 3 Voies / Altavoz 3 Vías

- CARBON GRAPHITE IMPP™ INTERLACED ARAMID FIBER CONE /
CÔNE EN FIBRES ARAMIDE ENTRELACÉES IMPP™ EN GRAPHITE DE CARBONE
- LIGHT WEIGHT BALANCED DOME MIDRANGE / HP MÉDIUM DU DÔME ÉQUILIBRÉ LÉGER

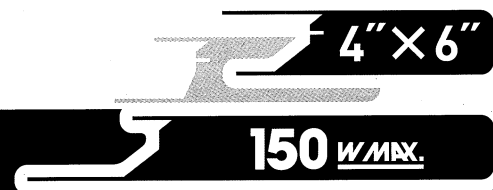

US/EURO
COMPATIBLE

ARAMID FIBER CONE /
CÔNE FIBRE ARAMIDE

IB INJECTION
MOLDED
CONE

CUSTOM-FIT / HP PERSONNALISÉS
GENERAL MOTORS • VOLKSWAGEN
MERCEDES-BENZ

TS-A4672R

3-Way Speaker

- MAX. MUSIC POWER 150 W
- NOMINAL POWER 20 W
- WOOFER 4"×6"
- MIDRANGE Ø7/8" DOME
- TWEETER Ø3/8" DOME
- IMPEDANCE 4 OHMS • SENSITIVITY 90 dB
- FREQUENCY RESPONSE 45 Hz TO 30 000 Hz
- GROSS WEIGHT 1.02 kg 2 lb 4 oz

4"×6" 150 W/MAX.



US/EURO
COMPATIBLE

ARAMID FIBER CONE

CUSTOM-FIT
GENERAL MOTORS • VOLKSWAGEN
MERCEDES-BENZ

Pioneer

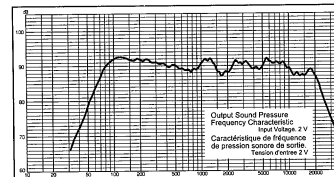

- PARTS INCLUDED
- PIÈCES COMPRISES

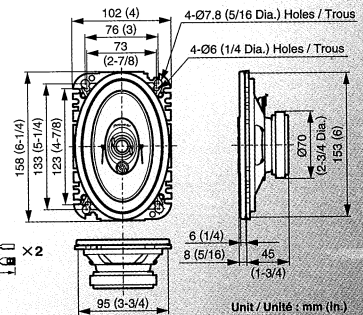
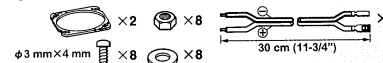





XCN/UC
1 PAIR / 1 PAIRE

Register your product at
<http://www.pioneerelectronics.com>

PIONEER CORPORATION

● PARTS INCLUDED
 ● PIÈCES COMPRIS
 ● PIEZAS INCLUIDAS
 ● PECAS INCLUIDAS

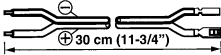
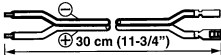
- ① _____  × 2
 ② _____ $\phi 3 \text{ mm} \times 4 \text{ mm}$  × 8
 ③ _____  × 8
 ④ _____  × 8
 ⑤ _____  × 1
 White cord Fil blanc Cordón blanco Fio bianco
 ⑥ _____  × 1
 Gray cord Fil gris Cordón gris Fio cinza

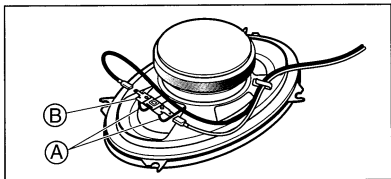

⚠️WARNING :

Handling the cord on this product or cords associated with accessories sold with the product will expose you to chemicals listed on proposition 65 known to the State of California and other governmental entities to cause cancer and birth defect or other reproductive harm.

Wash hands after handling.

⚠️CAUTION

1. Do not touch the speaker flexible wire (A).
2. Do not change the direction of the speaker terminal assembly (B).
3. Make sure lead and speaker terminals do not contact metal.
4. When making connections, refer also to the instruction manual of the car stereo used.

⚠️ATTENTION

1. Ne jamais toucher le fil flexible de haut-parleur (A).
2. Ne pas modifier l'orientation de plaquette de connexions du haut-parleur (B).
3. S'assurer que les fils et les bornes de haut-parleurs ne touchent pas une pièce métallique.
4. Le branchement s'opère après consultation de la notice d'instructions de l'autoradio qui est utilisé.

⚠️PRECAUCION

1. No se debe tocar el alambre flexible (A) del altavoz.
2. No cambiar la dirección del ensamblaje de terminal del altavoz (B).
3. Asegurarse de que los terminales del altavoz y el hilo conductor no están en contacto con el metal.
4. Para hacer la conexión consultar también el manual de instrucciones que se provee para el "reproductor".

⚠️PRECAUÇÃO

1. Não toque no fio flexível do alto-falante (A).
2. Não mude a direção de montagem do terminal do alto-falante (B).
3. Assegure-se de que o fio e os terminais do alto-falantes não entrem em contacto com metal.
4. Quando da realização das conexões, favor referir-se também ao manual de instruções do estereo de carro que está sendo usado.

- | |
|---|
| <ul style="list-style-type: none">● Do not fail to read the instructions on the flap to the opposite side.● Ne manquez pas de lire les instructions sur le volet sur le côté opposé.● Asegúrese de leer las instrucciones sobre la solapa al lado opuesto.● Não deixe de ler as intruções mencionadas na aba do lado oposto. |
|---|



PIONEER ELECTRONICS (USA) INC.

PIONEER ELECTRONICS OF CANADA, INC.

LIMITED WARRANTY
WARRANTY VALID ONLY IN COUNTRY OF PRODUCT PURCHASE

WARRANTY

Pioneer Electronics (USA) Inc. (PUSA), and Pioneer Electronics Of Canada, Inc. (POC), warrant that products distributed by PUSA in the U.S.A., and by POC in Canada that fail to function properly under normal use due to a manufacturing defect when installed and operated according to the owner's manual enclosed with the unit will be repaired or replaced with a unit of comparable value, at the option of PUSA or POC, without charge to you for parts or actual repair work.

THIS LIMITED WARRANTY APPLIES TO THE ORIGINAL OR ANY SUBSEQUENT OWNER OF THIS PIONEER PRODUCT DURING THE WARRANTY PERIOD PROVIDED THE PRODUCT WAS PURCHASED FROM AN AUTHORIZED PIONEER DISTRIBUTOR/DEALER IN THE U.S.A. OR CANADA. YOU WILL BE REQUIRED TO PROVIDE A SALES RECEIPT OR OTHER VALID PROOF OF PURCHASE SHOWING THE DATE OF ORIGINAL PURCHASE OR, IF RENTED, YOUR RENTAL CONTRACT SHOWING THE PLACE AND DATE OF FIRST RENTAL. IN THE EVENT SERVICE IS REQUIRED, THE PRODUCT MUST BE DELIVERED WITHIN THE WARRANTY PERIOD, TRANSPORTATION PREPAID, ONLY FROM WITHIN THE COUNTRY OF PURCHASE AS EXPLAINED IN THIS DOCUMENT.

PRODUCT WARRANTY PERIOD

Table with 2 columns: Product Type, Parts, Labor. Row: Car Stereo Products, 1 Year, 1 Year.

The warranty period for retail customers who rent the product commences upon the date product is first put into use (a) during the rental period or (b) retail sale, whichever occurs first.

WHAT IS NOT COVERED

IF THIS PRODUCT WAS PURCHASED FROM AN UNAUTHORIZED DISTRIBUTOR, THERE ARE NO WARRANTIES, EXPRESS OR IMPLIED, INCLUDING THE IMPLIED WARRANTY OF MERCHANTABILITY AND THE IMPLIED WARRANTY OF FITNESS FOR A PARTICULAR PURPOSE AND THIS PRODUCT IS SOLD STRICTLY "AS IS" AND "WITH ALL FAULTS". PIONEER SHALL NOT BE LIABLE FOR ANY CONSEQUENTIAL AND/OR INCIDENTAL DAMAGES.

PIONEER DOES NOT WARRANT ANY PRODUCT LISTED ABOVE WHEN IT IS USED IN A TRADE OR BUSINESS OR IN ANY INDUSTRIAL OR COMMERCIAL APPLICATION. THIS WARRANTY DOES NOT APPLY IF THE PRODUCT HAS BEEN SUBJECTED TO POWER IN EXCESS OF ITS PUBLISHED POWER RATING.

THIS WARRANTY DOES NOT COVER DISPLAY SCREENS DAMAGED BY STATIC, NON-MOVING, IMAGES APPLIED FOR LENGTHY PERIODS (BURN-IN).

THIS WARRANTY DOES NOT COVER THE CABINET OR ANY APPEARANCE ITEM, USER ATTACHED ANTENNA, ANY DAMAGE TO RECORDS OR RECORDING TAPES OR DISCS, ANY DAMAGE TO THE PRODUCT RESULTING FROM ALTERATIONS, MODIFICATIONS NOT AUTHORIZED IN WRITING BY PIONEER, ACCIDENT, MISUSE OR ABUSE, DAMAGE DUE TO LIGHTNING OR TO POWER SURGES, SUBSEQUENT DAMAGE FROM LEAKING, DAMAGE FROM INOPERATIVE BATTERIES, OR THE USE OF BATTERIES NOT CONFORMING TO THOSE SPECIFIED IN THE OWNER'S MANUAL.

THIS WARRANTY DOES NOT COVER THE COST OF PARTS OR LABOR WHICH WOULD BE OTHERWISE PROVIDED WITHOUT CHARGE UNDER THIS WARRANTY OBTAINED FROM ANY SOURCE OTHER THAN A PIONEER AUTHORIZED SERVICE COMPANY OR OTHER DESIGNATED LOCATION. THIS WARRANTY DOES NOT COVER DEFECTS OR DAMAGE CAUSED BY THE USE OF UNAUTHORIZED PARTS OR LABOR OR FROM IMPROPER MAINTENANCE.

ALTERED, DEFACED, OR REMOVED SERIAL NUMBERS VOID THIS ENTIRE WARRANTY

NO OTHER WARRANTIES

IN THE U.S.A. - PIONEER LIMITS ITS OBLIGATIONS UNDER ANY IMPLIED WARRANTIES INCLUDING, BUT NOT LIMITED TO, THE IMPLIED WARRANTIES OF MERCHANTABILITY AND FITNESS FOR A PARTICULAR PURPOSE, TO A PERIOD NOT TO EXCEED THE WARRANTY PERIOD. NO WARRANTIES SHALL APPLY AFTER THE WARRANTY PERIOD. SOME STATES DO NOT ALLOW LIMITATIONS ON HOW LONG AN IMPLIED WARRANTY LASTS AND SOME STATES DO NOT ALLOW THE EXCLUSIONS OR LIMITATIONS OF INCIDENTAL OR CONSEQUENTIAL DAMAGES, SO THE ABOVE LIMITATIONS OR EXCLUSIONS MAY NOT APPLY TO YOU. THIS WARRANTY GIVES YOU SPECIFIC LEGAL RIGHTS AND YOU MAY HAVE OTHER RIGHTS WHICH MAY VARY FROM STATE TO STATE.

IN CANADA - EXCEPT AS EXPRESSLY PROVIDED HEREIN, THERE ARE NO REPRESENTATIONS, WARRANTIES, OBLIGATIONS OR CONDITIONS, IMPLIED, STATUTORY OR OTHERWISE, APPLICABLE TO THIS PRODUCT.

TO OBTAIN SERVICE

In the U.S.A. or Canada to receive warranty service you need to present your sales receipt or your rental contract showing place and date of original owner's transaction.

USA - Please contact one of the following Pioneer partners to obtain service:

Your Authorized Pioneer Dealer - Your Pioneer Dealer may repair or replace your unit, or refer you to an Authorized Pioneer Service Company. Your sales receipt should list the contact information (phone number, fax, email, etc.) for your Dealer.

Your Authorized Pioneer Service Company - Can perform repairs for most Car Electronics products and can advise other options as applicable. Please access the Pioneer website at www.pioneerelectronics.com and click on Service and Support and select Authorized Service Locator to find the nearest Pioneer servicer.

Pioneer Electronics Service - Can advise the optimal service option for your model and geographic location. Please reference the information listed below and phone, email or access the Pioneer website to contact Pioneer.

CANADA - POC has a number of Authorized Service Companies should your product require service. Contact Pioneer of Canada as listed below to obtain a local service location.

Shipping Your Unit for Service - Please package it carefully and send it, transportation prepaid by a traceable, insured method, to an Authorized Service Company or Pioneer. Use adequate padding material to prevent damage in transit. Include your name, address and telephone number where you can be reached during business hours.

On all complaints and concerns in the U.S.A. call Customer Support at 1-800-421-1404, or, in Canada, call Customer Satisfaction at (905) 479-4411.

IN THE U.S.A.

For hook-up and operation of your unit or to locate an Authorized Service Company, please call or write:

PIONEER ELECTRONIC SERVICE, INC.
P.O. BOX 1760
LONG BEACH, CALIFORNIA 90801
1-800-421-1404
http://www.pioneerelectronics.com

IN CANADA

For additional information on this warranty, please call or write:

CUSTOMER SATISFACTION GROUP
PIONEER ELECTRONICS OF CANADA, INC.
300 ALLSTATE PARKWAY
MARKHAM, ON L3R 0P2
(905) 479-4411 1-877-283-5901
http://www.pioneerelectronics.com

DISPUTE RESOLUTION

IN THE U.S.A. - Following our response to any initial request to Customer Support, should a dispute arise between you and Pioneer, Pioneer makes available its Complaint Resolution Program to resolve the dispute. The Complaint Resolution Program is available to you without charge. You are required to use the Complaint Resolution Program before you exercise any rights under, or seek any remedies, created by Title I of the Magnuson-Moss Warranty-Federal Trade Commission Improvement Act, 15 U.S.C. 2301 et seq. To use the Complaint Resolution Program call 1-800-421-1404 and explain to the customer service representative the problem you are experiencing, steps you have taken to have the product repaired during the warranty period and the name of the authorized Distributor/Dealer from whom the Pioneer product was purchased. After the complaint has been explained to the representative, a resolution number will be issued. Within 40 days of receiving your complaint, Pioneer will investigate the dispute and will either: (1) respond to your complaint in writing informing you what action Pioneer will take, and in what time period, to resolve the dispute; or (2) respond to your complaint in writing informing you why it will not take any action.

IN CANADA - Call the Customer Satisfaction Manager at (905) 946-7446 to discuss your complaint and to obtain a prompt resolution.

RECORD THE PLACE AND DATE OF PURCHASE FOR FUTURE REFERENCE

Model No. Serial No. Purchase Date

Purchased From

KEEP THIS INFORMATION AND YOUR SALES RECEIPT IN A SAFE PLACE